

EN

DE

NL

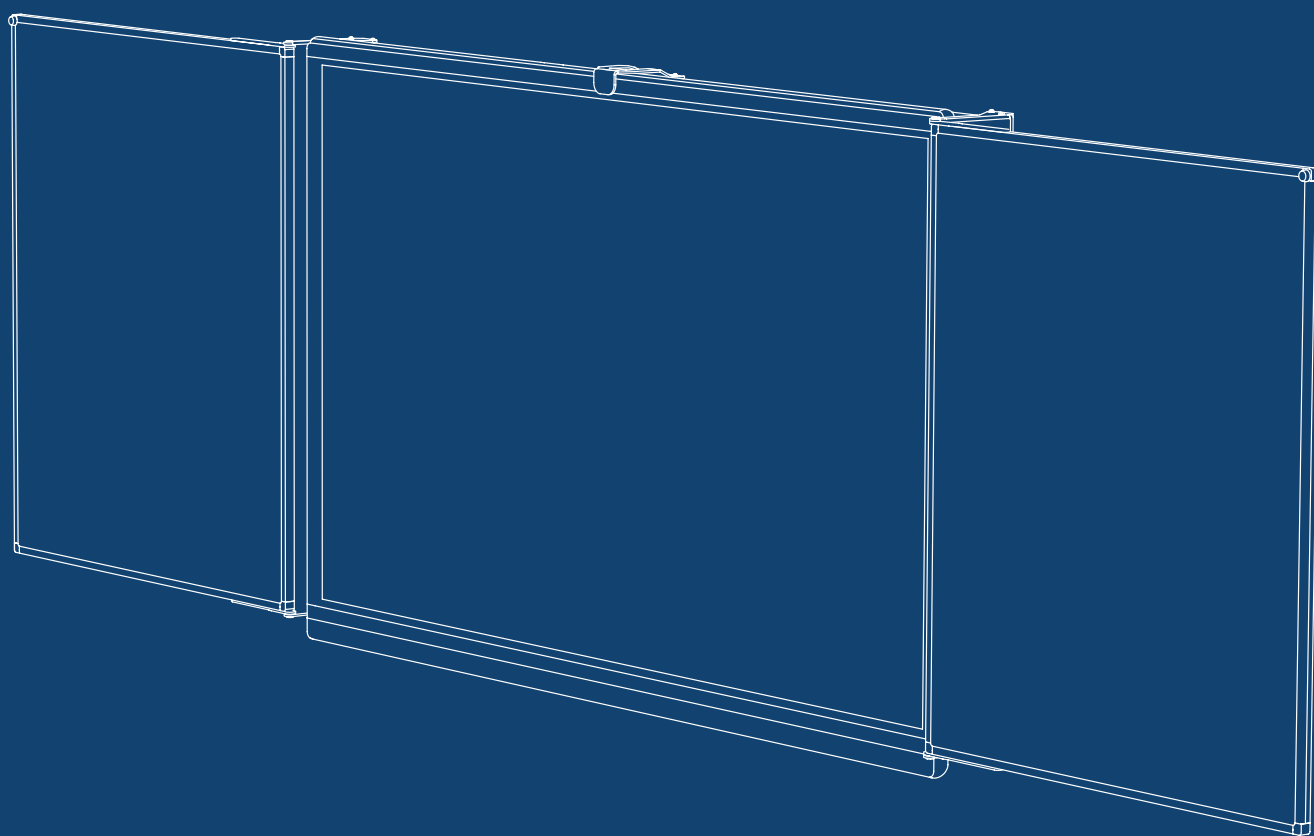

User Manual

Prowise iPro Whiteboard Extension Kit G2
for Prowise Touchscreen One and Prowise Touchscreen Ten

PrOwise



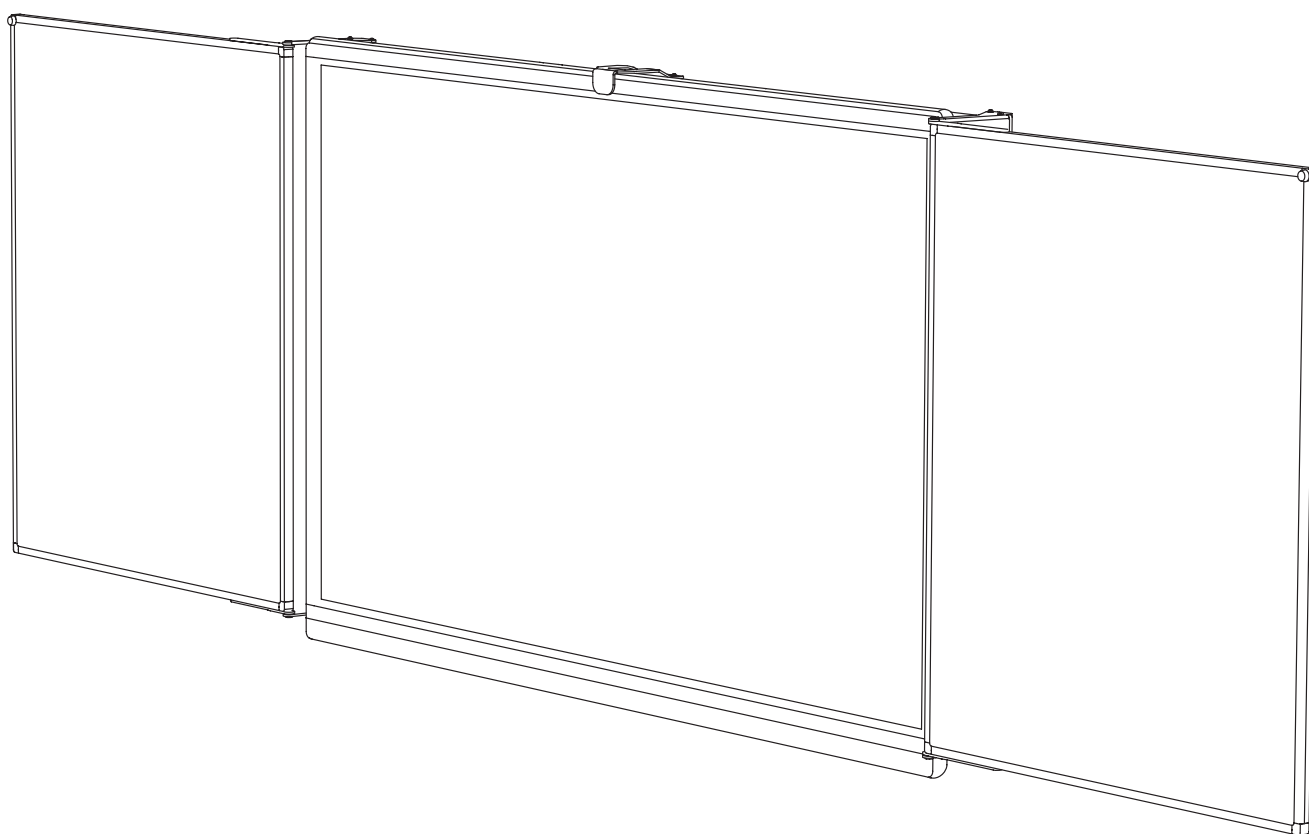

User Manual

Prowise iPro Whiteboard Extension Kit G2
for Prowise Touchscreen One and Prowise Touchscreen Ten

PrOwise

Table of Contents

Installation guidelines	4
Where can I go if I have questions?	4
Safety instructions	4
What is in the box?	8
Necessities	9
Technical installation of the Whiteboard Extension Kit G2	11

Installation guidelines

Please consider the following guidelines before installing the whiteboard extension kit G2.

- 1 The wall to which the lift is assembled, needs to be capable of supporting twice the combined weight of the touchscreen and the whiteboards.
- 2 The maximum load of the Prowise lifts is 150 kg. The mobile lifts cannot support systems larger than 75 inches.
- 3 Clear the wall from any obstacles. To prevent the risk of entrapment, a minimum distance of 10 cm to the left, right and above the screen and a minimum of 12 cm below it must be respected between the screen and any other objects around it such as accessories, whiteboards and keyboard holders.
- 4 Before installing the whiteboards, please read the supplied safety guide carefully.
- 5 The Whiteboard Extension Kit G2 is made for Prowise Touchscreen One and Prowise Touchscreen Ten.

Safety requirements

Please read the supplied safety regulations carefully before installing and using the Prowise whiteboards. Please follow warnings and instructions closely and always keep the **Safety Guide and User Manual at hand.**



Where can I go if I have questions?

In case you have any additional questions about the installation or use of the Prowise whiteboards, our colleagues at the Customer Service department are happy to help.

✉ Please send an email to: service@prowise.com

Inhalt

Installationsvorschriften	5
Ansprechpartner bei Fragen	5
Sicherheitshinweise	5
Lieferumfang	8
Das benötigen Sie außerdem	9
Technische Installation des Whiteboard Extension Kits G2	11

04 EN

05 DE

06 NL

Installationsvorschriften

Vor der Installation des Whiteboard Extension Kits G2, bitte folgende Anweisungen zu beachten.

- 1 Die Wand, an welcher der Lift befestigt ist, muss für eine Tragkraft ausgelegt sein, die dem Zweifachen des Gewichts des Touchscreens entspricht.
- 2 Die maximale Tragkraft der Prowise Lifte beträgt 150 kg. Auf mobilen Liften dürfen nur Systeme mit einer Größe von maximal 75 Zoll installiert werden.
- 3 Stellen Sie sicher, dass die Wand frei von Hindernissen ist. Um die Gefahr eines Einklemmens zu vermeiden, muss nach der Installation links, rechts und oberhalb des Bildschirms mindestens 10 cm Platz bleiben, nach unten mindestens 12 cm. Diese Abstände verstehen sich inklusive aller Zubehörteile wie Whiteboards und Tastaturhalterungen.
- 4 Machen Sie sich vor Installation der Whiteboards mit den im Lieferumfang enthaltenen Sicherheitshinweisen vertraut.
- 5 Das Whiteboard Extension Kit G2 ist für die Prowise Touchscreen One und Prowise Touchscreen Ten ausgelegt.

Sicherheitsvorschriften

Machen Sie sich vor Installation und Gebrauch der Prowise Whiteboards mit den im Lieferumfang enthaltenen Sicherheitshinweisen vertraut. Beachten Sie sorgfältig alle Warnhinweise und bewahren Sie sowohl die Sicherheitshinweise als auch die Bedienungsanleitung stets in Reichweite auf.



Ansprechpartner bei Fragen

Bei Fragen zur Installation oder Verwendung der Prowise Whiteboards sind unsere Mitarbeiter vom Kundendienst gern für Sie da.

✉ Per E-Mail an: service@prowise.de

Inhoudsopgave

Installatierichtlijnen	6
Waar kan ik met vragen terecht?	6
Veiligheidsinstructies	6
Wat zit er in de verpakking?	8
Benodigdheden	9
Technische installatie van de Whiteboard Extension Kit G2	11

Installatierichtlijnen

Voordat je start met het installeren van de whiteboard extension kit G2, is het belangrijk dat je onderstaande richtlijnen in acht neemt.

- 1 De muur waaraan de lift of muurplaat is bevestigd, moet een draagvermogen hebben van twee maal het gezamenlijke gewicht van het touchscreen en de whiteboarden.
- 2 De maximale belasting van de Prowise liften is 150 kg. Op mobiele liften mogen geen systemen groter dan 75 inch geïnstalleerd worden.
- 3 Zorg ervoor dat de wand vrij is van obstakels. Om beknellingsgevaar te voorkomen moet er na de installatie te allen tijde rondom het scherm inclusief eventuele accessoires, zoals whiteboarden en toetsenbordhouders, naar links, rechts en boven minstens 10 cm ruimte vrij blijven en naar onder minstens 12 cm.
- 4 Lees voordat je de lift whiteboarden installeert de meegeleverde safety instructions goed door.
- 5 De Whiteboard Extension Kit G2 is gemaakt voor de Prowise Touchscreen One en Prowise Touchscreen Ten.

Waar kan ik met vragen terecht?

Mocht je onverhoopt toch nog vragen hebben over de installatie of het gebruik van de Prowise whiteboarden, dan zitten onze collega's van Customer Service uiteraard voor je klaar.

✉ Mail naar: service@prowise.com

Veiligheidsvoorschriften

Lees voordat je de Prowise whiteboarden installeert en in gebruik neemt de meegeleverde veiligheidsvoorschriften. Volg eventuele waarschuwingen zorgvuldig op en bewaar de veiligheidsvoorschriften en gebruikershandleiding altijd binnen handbereik.



What's in the box?

DE Lieferumfang | NL Wat zit er in de verpakking?

- 1 2x Prowise Whiteboards
- 2 2x VESA clamps
- 3 2 x crossbars 40x40
- 4 2x sidebars 40x20
- 5 4x hinges (2x left, 2x right)
- 6 1x safety clamp
- 7 18x M6x20 (black)
- 8 8x M6x60
- 9 2x M5x70
- 10 18x self-tapping screws 4.5x25
- 11 2x bumper feet white
- 12 2x bumper feet black
- 13 User manual
- 14 Safety instructions

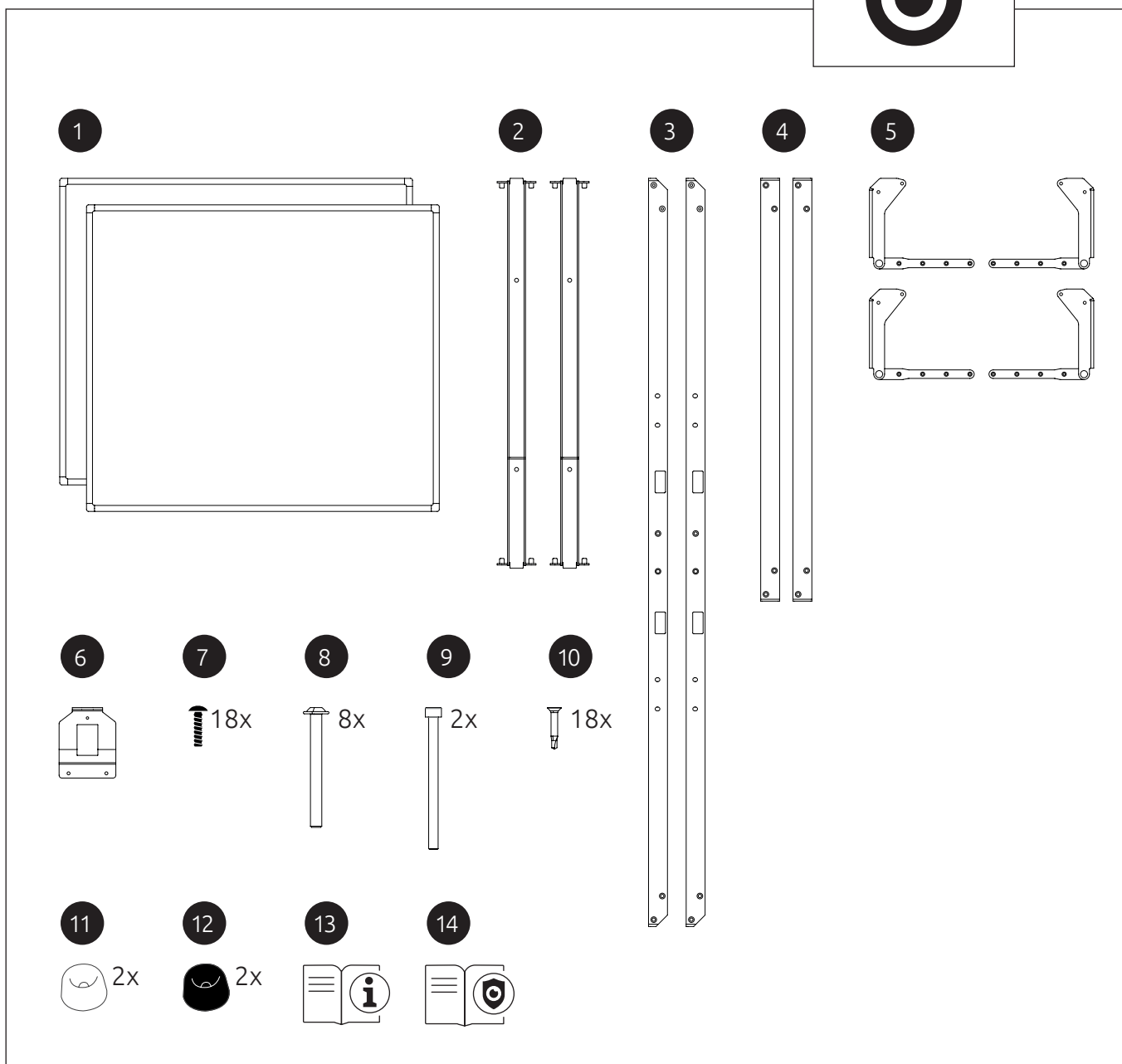
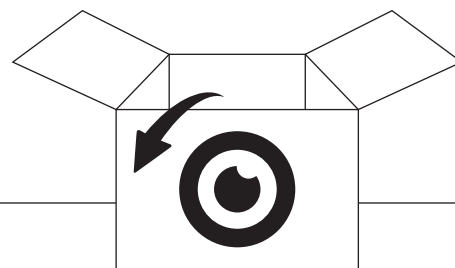

You need

DE Das benötigen Sie außerdem | NL Benodigdheden

04	EN
05	DE
06	NL

- 1 Bit holder
- 2 Bit hex key 4 mm
- 3 Bit hex key 5 mm
- 4 Bit ttap 20
- 5 Drill
- 6 Drill 3 mm

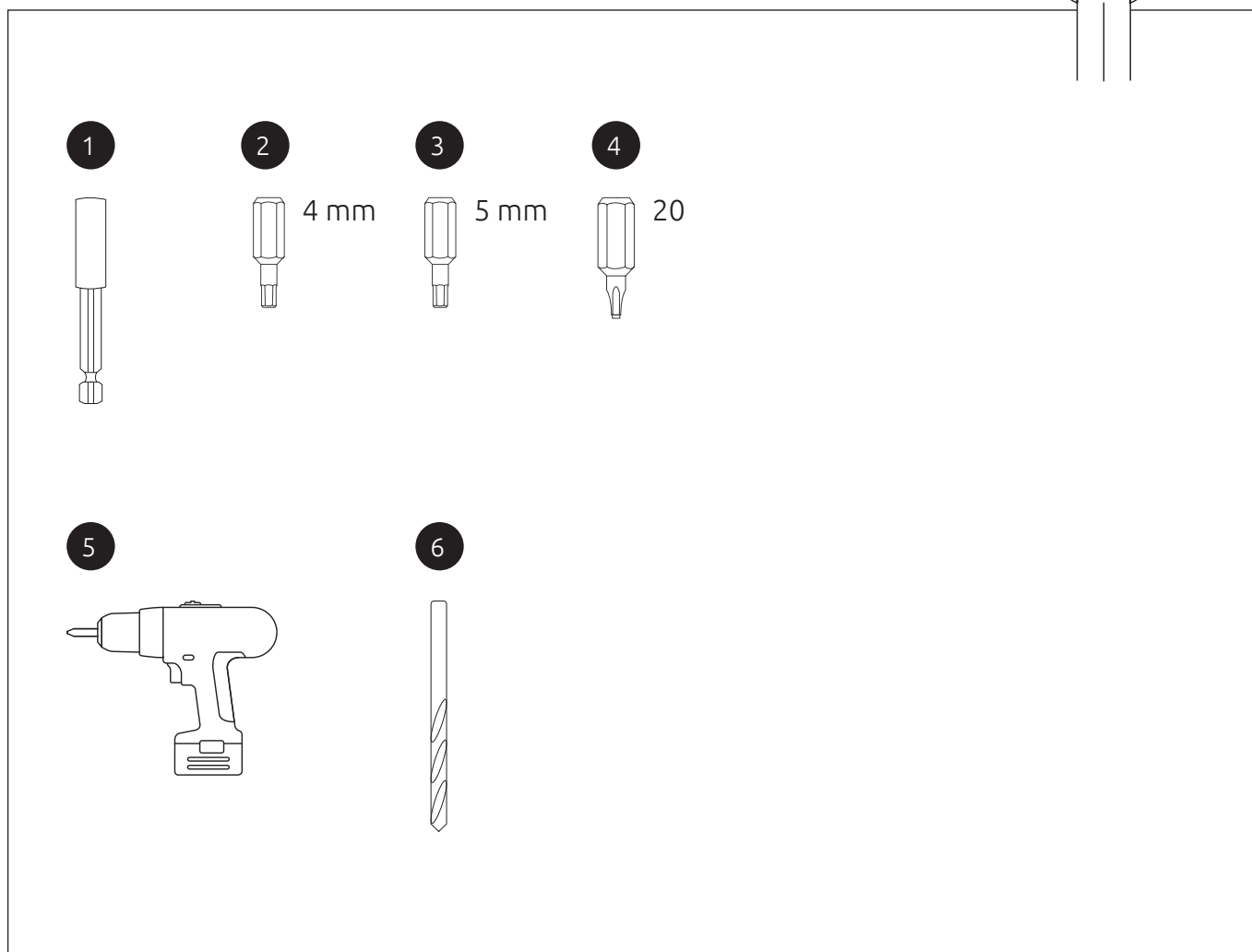
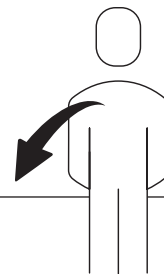

VESA brackets assembly positions

DE Montagepositionen Vesa-Halterungen | NL VESA brackets montage posities

Touchscreen One 65"

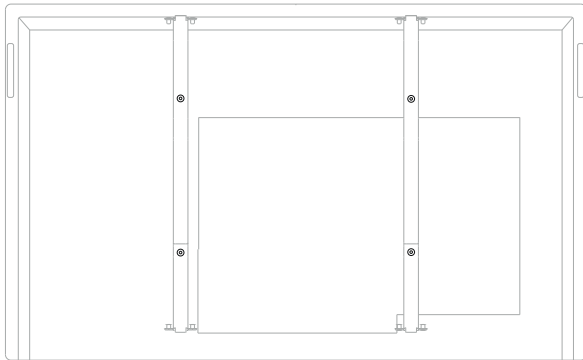

Touchscreen Ten 65"

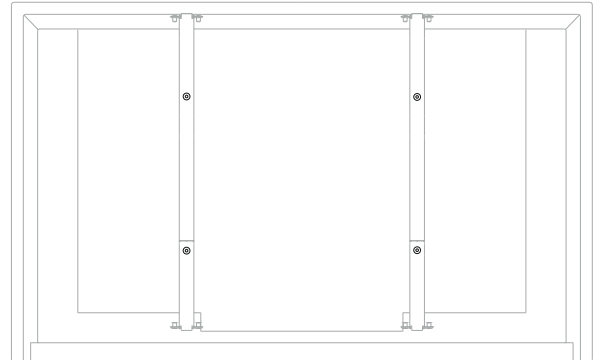

Touchscreen One 75"

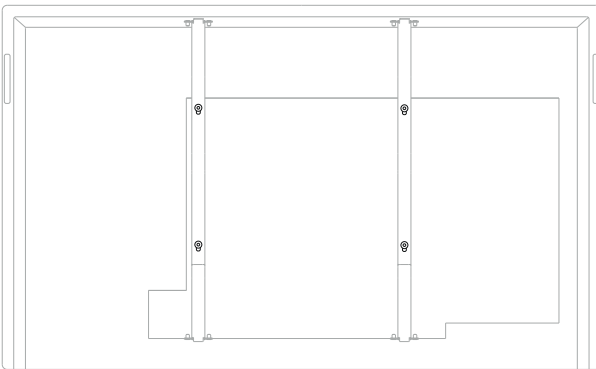

Touchscreen Ten 75"

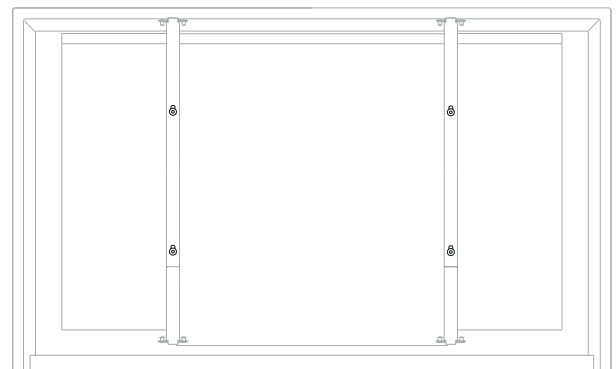

Touchscreen One 86"

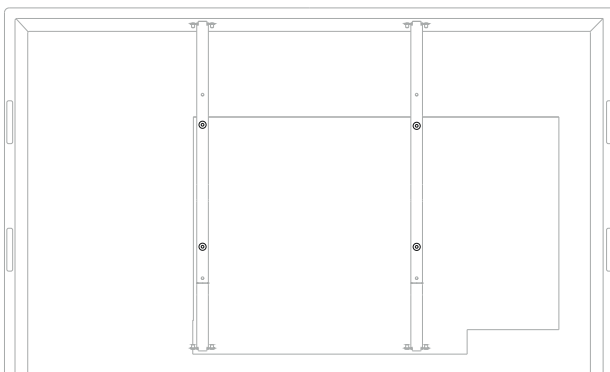

Touchscreen Ten 86"

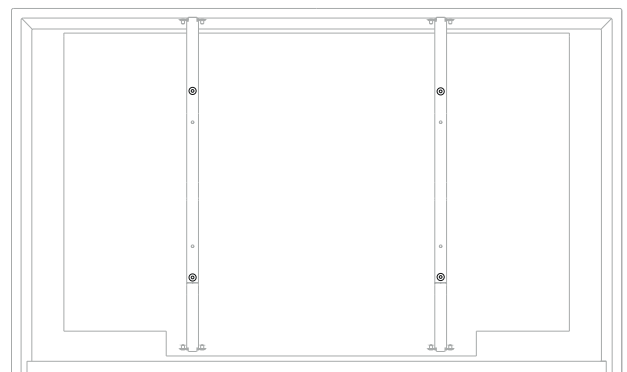

Installation Whiteboard Extension Kit

DE Installation Whiteboard Extension Kit | NL Installatie Whiteboard extension kit

04	EN
05	DE
06	NL

1

4x M8x20*

Hex 5mm

**Supplied with Prowise Touchscreen and/or Prowise Lift System*

2

Hex 4mm

8x M6x60

3

Hex 4mm

8x M6x20

4

Hex 4mm

8x M6x20

5

Hex 4mm

2x M6x20

6

7



Hex 4mm

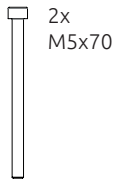

2x M5x70

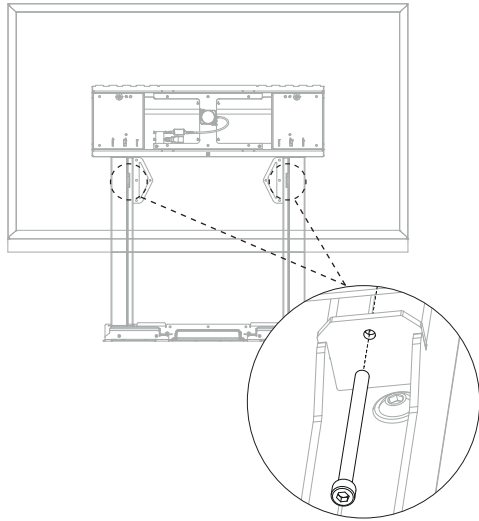

8

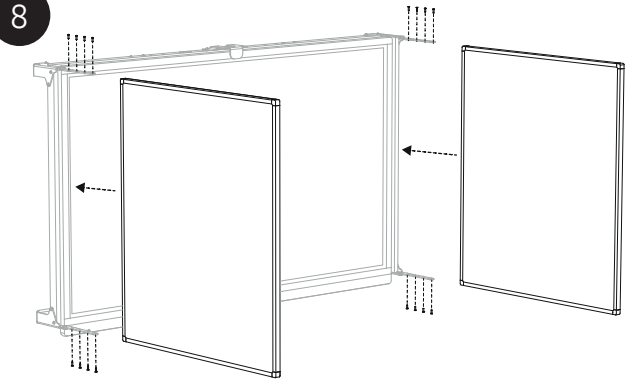

Bit ttap 20

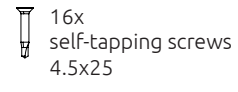

16x self-tapping screws 4.5x25

9



Hex 4mm



8x

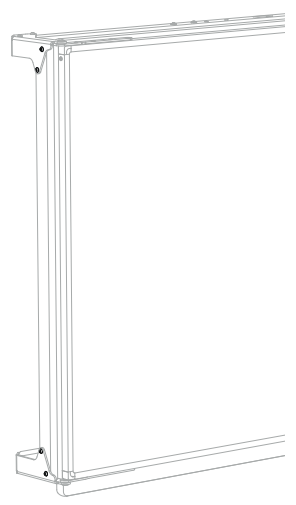

10

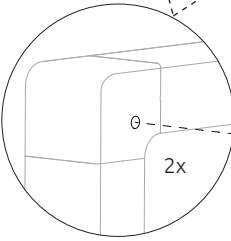
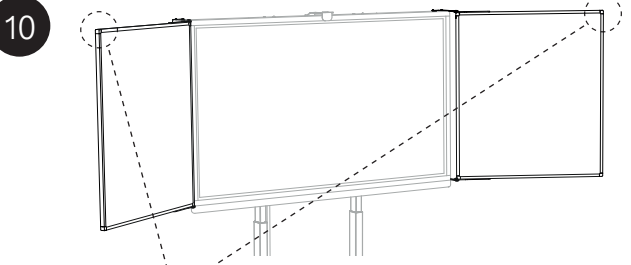

2x

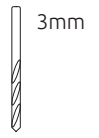

3mm

11



2x White or Black

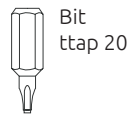
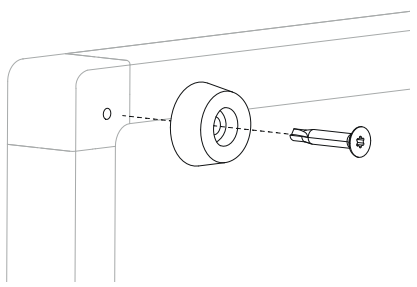

Bit ttap 20

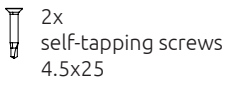

2x self-tapping screws 4.5x25

12

Prowise MOVE camera (optional)

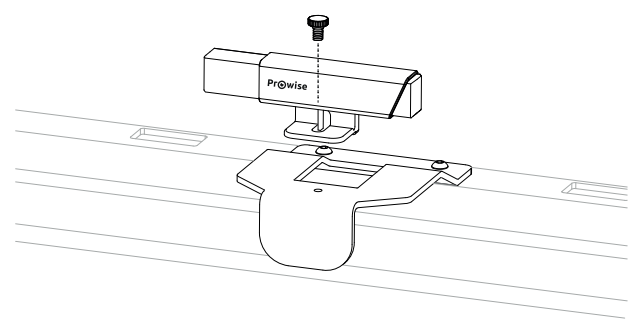

13

Keyboard Tray G2 (optional) on G2 Lift

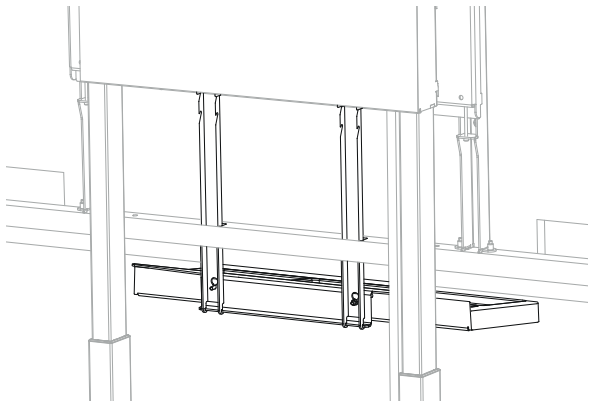

14

Keyboard Tray G1 (optional) on G1 Lift

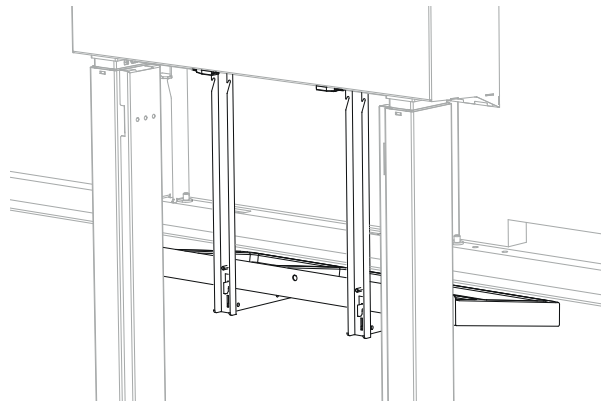



Let education speak

Pr@wise

www.prowise.com

